

TECHNICAL MANUAL

OPERATOR'S, ORGANIZATIONAL, DIRECT SUPPORT,  
AND GENERAL SUPPORT MAINTENANCE  
MANUAL INCLUDING REPAIR PARTS LIST

FOR

TESTER, CYLINDER

MODEL 2093A

(STEWART-THOMAS INDUSTRIES INC.)

(NSN 4910-00-250-2423)



TECHNICAL MANUAL

No. 9-4910-582-14&amp;P

HEADQUARTERS  
DEPARTMENT OF THE ARMY  
WASHINGTON, DC, 26 September 1980

OPERATOR'S, ORGANIZATIONAL, DIRECT SUPPORT,  
AND GENERAL SUPPORT MAINTENANCE MANUAL  
INCLUDING REPAIR PARTS LIST  
FOR  
**TESTER, CYLINDER**  
**MODEL 2093A**  
**(NSN 4910-00-250-2423)**

**REPORTING ERRORS AND RECOMMENDING IMPROVEMENTS**

You can help improve this manual. If you find any mistakes or if you know of a way to improve the procedures, please let us know. Mail your letter, DA Form 2028 (Recommended Changes to Publications and Blank Forms), or DA Form 2028-2, located in the back of this manual direct to: Commander, US Army Armament Materiel Readiness Command, ATTN: DRSAR-MAS, Rock Island, IL 61299. A reply will be furnished directly to you.

**NOTE**

This manual is published for the purpose of identifying an authorized commercial **manual** for the use of the personnel to whom this cylinder tester is issued.

Manufactured by: Stewart-Thomas Industries, Inc.  
100 Cabot Street  
West Babylon, NY 11704

Procured under Contract No. DAAK09-78-C-4437

This technical manual is an authentication of the manufacturers' commercial literature and does not conform with the format and content specified in AR 310-3, Military Publications. This technical manual does, however, contain available information that is essential to the operation and maintenance of the equipment.



INSTRUCTIONS FOR REQUISITIONING PARTS  
NOT IDENTIFIED BY NSN

When requisitioning parts not identified by National Stock Number, it is mandatory that the following information be furnished the supply officer.

- 1 - Manufacturer's Federal Supply Code Number- 31077
- 2 - Manufacturer's Part Number exactly as listed herein.
- 3 - Nomenclature exactly as listed herein, including dimensions, if necessary.
- 4 - Manufacturer's Model Number - Model 2093A
- 5 - Manufacturer's Serial Number (End Item)
- 6 - Any other information such as Type, Frame Number, and Electrical Characteristics, if applicable.
- 7 - If DD Form 1348 is used, fill in all blocks except 4, 5, 6, and Remarks field in accordance with AR 725-50.

Complete Form as Follows:

- (a) In blocks 4, 5, 6, list manufacturer's Federal Supply Code Number - 31077 followed by a colon and manufacturer's Part Number for the repair part.
- (b) Complete Remarks field as follows:
 

Noun:	(nomenclature of repair part)
For:	NSN: 4910-00-250-2423
Manufacturer:	Stewart-Thomas Industries, Inc.

Model: 2093A  
Serial: (of end item)

Any other pertinent information such as Frame Number, Type, Dimensions, etc.



## OPERATING INSTRUCTIONS

### MODEL 2093A

### COMPRESSION TESTER

The Model 2093A tester is equipped with a dial calibrated from 0 to 300 lbs. pressure. A valve, located in the bottom of the check valve fitting, is provided to release the air pressure in the gauge.

A set of adapters, Figure 1, with threads to match the spark plugs of various engines is provided. A flexible extension is also furnished for use in restricted places. The cone adapter fitting is used for quick succession cylinder tests.

**COMPRESSION TEST.** The engine oil level, grade and cleanliness should be noted before making this test. When removing spark plugs for a compression test, first loosen the plugs slightly and then with an air hose blow out all the accumulation of dirt and foreign substances, which usually become pocketed around the spark plug. This will prevent a particle of foreign matter from dropping into the combustion chamber and becoming lodged under a valve. A valve thus held open will cause an erroneous compression reading of the cylinder. After the plugs are removed, it is a good plan to apply the air hose for blowing out the combustion chambers. Observe the spark plugs as they are removed for evidence of fouling, burning, heat range, etc.

**The engine should be up to normal operating temperature before starting this test to assure normal oil and metal expansion conditions.**

**Crank the engine with the starting motor with the ignition OFF.** In case of ignition switch-operated starting motor, ground ignition coil high-tension wire and use the ignition switch.

When making a compression test of an engine, the operator should take care to see that the highest gauge reading is obtained for each cylinder with the same number of turns of the starting motor. Usually about eight turns (which easily can be counted) of the motor is sufficient for each cylinder.

During this process if the operator carefully watches the gauge hand, a sticking valve easily may be detected. The hand progressively rises with each revolution of the starting motor until no further rise is obtained. The indicated pressure on the gauge represents the maximum compression pressure under the prevailing conditions.

Should the hand remain fixed at any one of the "beats" or revolutions of the starting motor and then again rise, the point where it lagged indicates a valve sticking in the open position. Compression pressures will be found to be higher in modern engines than for older models.

With the pistons, rings, valves and gaskets in good condition, maximum readings on all cylinders should be uniform within plus or minus 5 lbs. of specified pressures.

The maximum overall readings will vary slightly according to the altitude, but are influenced considerably by overall engine temperatures, oil viscosity, cranking speed, valve settings, etc.

Low readings on adjacent cylinders will ordinarily indicate gasket leakage between cylinders.

Low cylinder indication - particularly in one cylinder - indicates either improper valve seating or piston and ring blow-by.

In order to re-check, heavy sealing oil may be squirted onto the heads of all of the pistons and a re-check similar to the first test carried out.

PREVENTIVE MAINTENANCE. All parts of the equipment should be wiped clean and dried after use and retained in the carrying case to prevent damage.

TROUBLESHOOTING. Should a pressure drop occur when reading the pressure gage, pressurize the unit with compressed air; Caution: Do not exceed 300 psi. Submerge unit in water up to the stem of the Pressure Gage. Do not submerge Pressure Gage. Bubbles will appear at the leak. Tighten as is necessary and repeat test with unit pressurized.



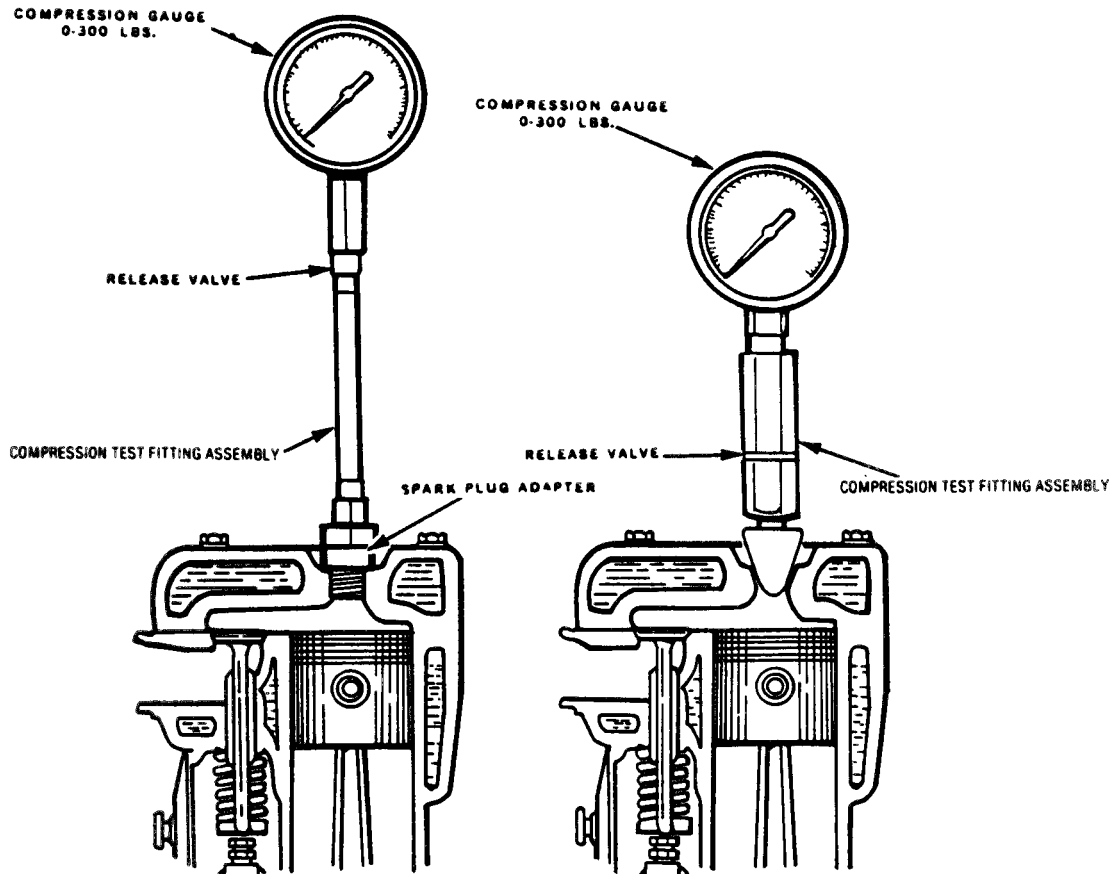

—Diagram showing method of using compression gauge. (Engine must be at operating temperature.) When spark plugs are replaced after compression test new plug gaskets of the type furnished with plug should be used.

PARTS LIST FOR MODEL 2093A  
 COMPRESSION TESTER

FIGURE 1

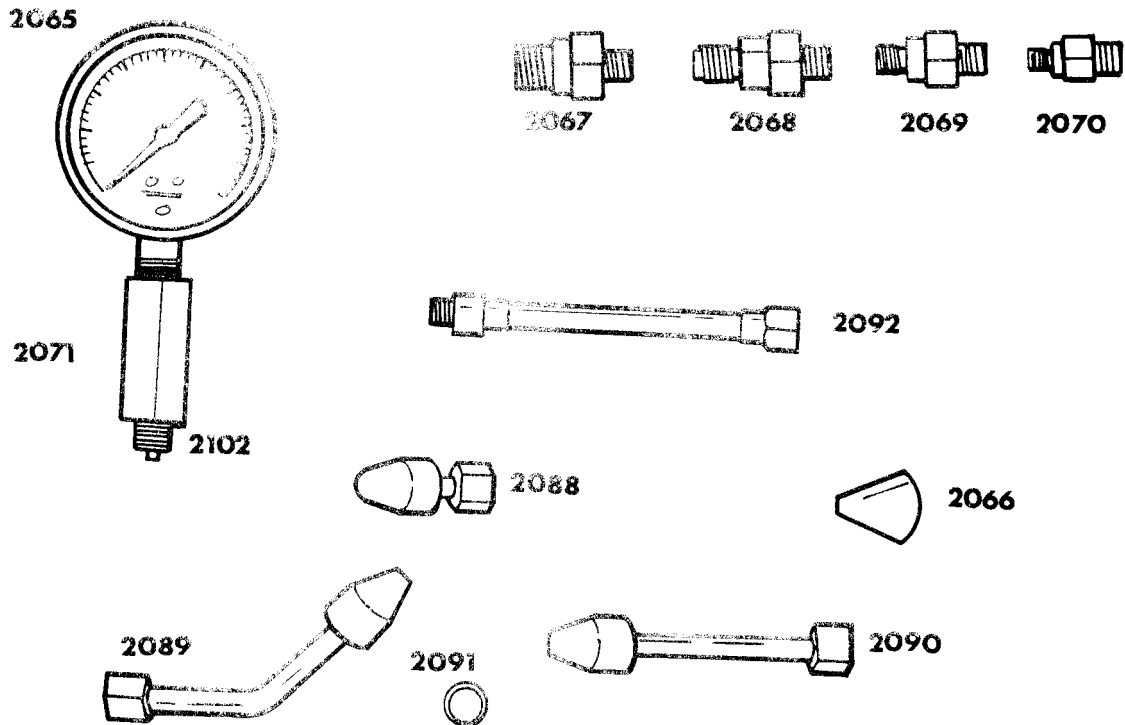

PART NUMBER	DESCRIPTION	NUMBER REQUIRED
2065	Compression Gauge 0-300 lbs.	1
2066	Cone Type Rubber Adapter	2
2067	Spark Plug Adapter 10MM	1
2068	Spark Plug Adapter 14MM	1
2069	Spark Plug Adapter 18MM	1
2070	Spark Plug Adapter 7/8 in.	1
2071	Check Valve Fitting	1
2082	Carrying Case (not shown)	1
2088	3" Universal Adapter with Rubber Cone	1
2089	135° Universal Adapter with Rubber Cone	1
2090	6-1/4" Universal Adapter with Rubber Cone	1
2091	O Ring	2
2092	Flexible Compression Hose Adapter	1
2102	Relief Valve	1

By Order of the Secretary of the Army:

E. C. MEYER  
*General, United States Army*  
*Chief of Staff*

Official:

J. C. PENNINGTON  
*Major General, United States Army*  
*The Adjutant General*



RECOMMENDED CHANGES TO EQUIPMENT TECHNICAL PUBLICATIONS



THEN... JOT DOWN THE DOPE ABOUT IT ON THIS FORM, CAREFULLY TEAR IT OUT, FOLD IT AND DROP IT IN THE MAIL!

SOMETHING WRONG WITH THIS PUBLICATION?

FROM: (PRINT YOUR UNIT'S COMPLETE ADDRESS)

Your mailing address

DATE SENT

Date you filled out this form

PUBLICATION NUMBER

TM 9-4910-582-14&P

PUBLICATION DATE

September 1980

PUBLICATION TITLE

Operating Manual for  
Cylinder Tester

BE EXACT... PIN-POINT WHERE IT IS

PAGE NO.	PARA-GRAPH	FIGURE NO.	TABLE NO.
3			1-2

IN THIS SPACE TELL WHAT IS WRONG AND WHAT SHOULD BE DONE ABOUT IT:

Screw (4) is 1/8-in., not 1/4-in.

SAMPLE

TEAR ALONG PERFORATED LINE

PRINTED NAME, GRADE OR TITLE, AND TELEPHONE NUMBER

SIGN HERE:

Your name

DA FORM 2028-2  
1 JUL 79

PREVIOUS EDITIONS ARE OBSOLETE.

P.S.—IF YOUR OUTFIT WANTS TO KNOW ABOUT YOUR RECOMMENDATION MAKE A CARBON COPY OF THIS AND GIVE IT TO YOUR HEADQUARTERS.

FILL IN YOUR  
UNIT'S ADDRESS

FOLD BACK

DEPARTMENT OF THE ARMY

POSTAGE AND FEES PAID  
DEPARTMENT OF THE ARMY  
DOD 314



OFFICIAL BUSINESS  
PENALTY FOR PRIVATE USE \$300

Commander  
US Army Armament Materiel Readiness Command  
ATTN: DRSAR-MAS  
Rock Island, IL 61299

TEAR ALONG PERFORATED LINE

RECOMMENDED CHANGES TO EQUIPMENT TECHNICAL PUBLICATIONS



THEN... JOT DOWN THE DOPE ABOUT IT ON THIS FORM, CAREFULLY TEAR IT OUT, FOLD IT AND DROP IT IN THE MAIL!

**SOMETHING WRONG WITH THIS PUBLICATION?**

FROM: (PRINT YOUR UNIT'S COMPLETE ADDRESS)

DATE SENT

PUBLICATION NUMBER

TM 9-4910-582-14&P

PUBLICATION DATE

September 1980

PUBLICATION TITLE

Operating Manual for  
Cylinder Tester

BE EXACT... PIN-POINT WHERE IT IS

PAGE  
NO.

PARA-  
GRAPH

FIGURE  
NO.

TABLE  
NO.

IN THIS SPACE TELL WHAT IS WRONG  
AND WHAT SHOULD BE DONE ABOUT IT:

TEAR ALONG PERFORATED LINE

PRINTED NAME, GRADE OR TITLE, AND TELEPHONE NUMBER

SIGN HERE:

DA FORM 2028-2  
1 JUL 79

PREVIOUS EDITIONS  
ARE OBSOLETE.

P.S.--IF YOUR OUTFIT WANTS TO KNOW ABOUT YOUR  
RECOMMENDATION MAKE A CARBON COPY OF THIS  
AND GIVE IT TO YOUR HEADQUARTERS.

FILL IN YOUR  
UNIT'S ADDRESS

FOLD BACK

DEPARTMENT OF THE ARMY

POSTAGE AND FEES PAID  
DEPARTMENT OF THE ARMY  
DOD 314



OFFICIAL BUSINESS  
PENALTY FOR PRIVATE USE \$300

Commander  
US Army Armament Materiel Readiness Command  
ATTN: DRSAR-MAS  
Rock Island, IL 61299

TEAR ALONG PERFORATED LINE





FILL IN YOUR  
UNIT'S ADDRESS

FOLD BACK

DEPARTMENT OF THE ARMY

\_\_\_\_\_  
\_\_\_\_\_

OFFICIAL BUSINESS  
PENALTY FOR PRIVATE USE \$300

POSTAGE AND FEES PAID  
DEPARTMENT OF THE ARMY  
DOD 314



TEAR ALONG PERFORATED LINE

Commander  
US Army Armament Materiel Readiness Command  
ATTN: DRSAR-MAS  
Rock Island, IL 61299



FILL IN YOUR  
UNIT'S ADDRESS

FOLD BACK

TEAR ALONG PERFORATED LINE

DEPARTMENT OF THE ARMY

POSTAGE AND FEES PAID  
DEPARTMENT OF THE ARMY  
DOD 314



OFFICIAL BUSINESS  
PENALTY FOR PRIVATE USE \$300

Commander  
US Army Armament Materiel Readiness Command  
ATTN: DRSAR-MAS  
Rock Island, IL 61299



SPECIAL FOLIO  
CLASS FINE ELLS

PC451

USA  
VIA AIR MAIL  
CLASS FINE ELLS  
CLASS FINE ELLS  
CLASS FINE ELLS

TM 9-4910-582-14&P — CYLINDER TESTER — 1980

TM 9-4910-582-14&P  
CLASS FINE ELLS  
CLASS FINE ELLS  
CLASS FINE ELLS

CLASS FINE ELLS  
CLASS FINE ELLS  
CLASS FINE ELLS